

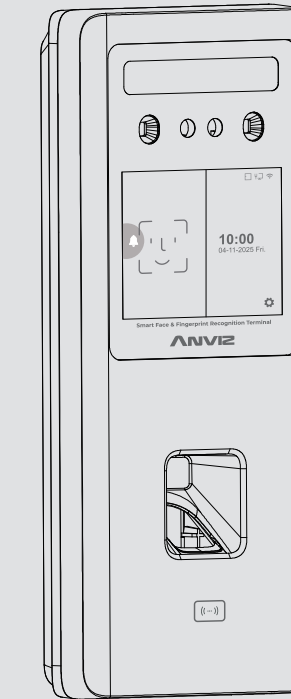

W2 Face User Guide

Smart Face & Fingerprint Recognition Terminal V1.0



www.anviz.com

Before Starting

Hardware Safety Instructions

Observe the following instructions to use the product safely and prevent any risk of injury or property damage.

Do not use oily water or sharp objects to stain or damage the display screen. Please gently wipe the screen and panel with soft materials. Avoid scrubbing with water or detergent.

Fragile parts are used in the equipment, please avoid operations such as falling, crashing, bending or heavily pressing.

The optimal working environment of W2 Face is indoor. The device function fully under temperature: -10°C~50°C (14°F~122°F). The best performance is between: 15°C~32°C (59°F~89.6°F). The device will be less effective if exceeds these ranges.

The recommended power of W2 Face terminal is DC 12V ~ 2A. The device will function less effective in case the power supply cable extends too long.

Terms & Policies

Before using all ANVIZ products, please read all applicable terms rules, policies and usage provisions found at www.anviz.com/privacypolicy and www.anviz.com/anviz-biometric-data-retention-policy. By using your ANVIZ products, you agree to be bound by the Terms & Policies.

Parts List



Appearance Description

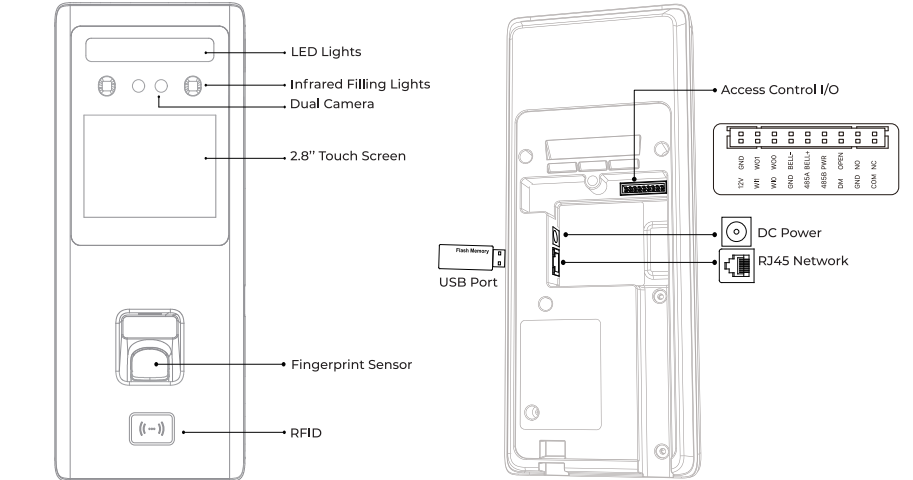

Features	Power Input	Wiegand Output		Active Doorbell		Passive Doorbell	Exit Button	Relay Output	
Num.	②	④	④	②	②	②	④	②	②
Table Color	Black	Yellow	Blue	Green	Black	Purple	Red	Blue	Black
Fuction	12V	Wiegand Input		RS485		Door Sensor Detection		COM	
Numbers.	①	③	⑤	⑦	⑨	⑪	⑬	⑮	⑰
Table Color	Red	Organge	Brown	White	Red	Gray	White	Brown	Red

Important Notice
Please follow the wiring diagram as it is displayed. Damaged products due to improper wiring are not covered under the product warranty.

Installation

The Sunlight and Hard Light may lead to big difference between site image and registered image; backlight, side-light and strong light will influence the recognition experience. (Notice: from the view of human eyes, the color changes on face skin may result in wrong recognition of identity; under exposure area, no matter large or small, may influence the identity judgement)

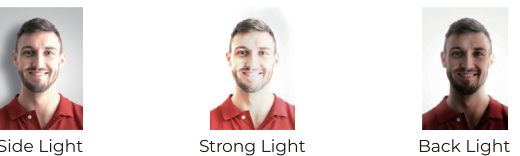

Device shall be installed in places avoiding backlight, side-light, strong light and direct sunlight.

- The recommended place for installation (Please keep 3m away from the window, or does not influenced by sunlight, can be considered for installation)
- Backlight, side-light or direct strong light, not suitable for installation.
- Other areas, install in suitable places according to actual light impact.
- Hard Light
- Curtain
- Door
- Wall
- Glass Window or Class Wall

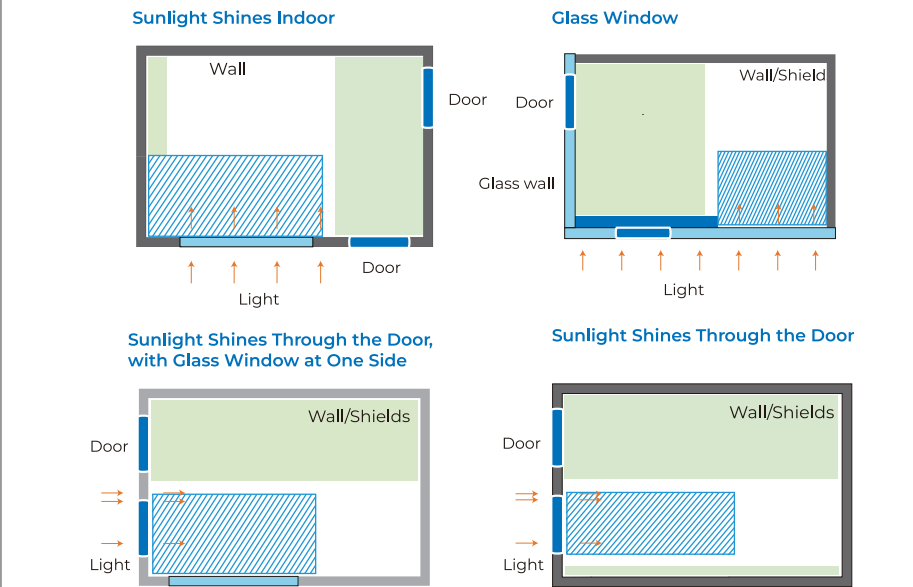

Installation Position

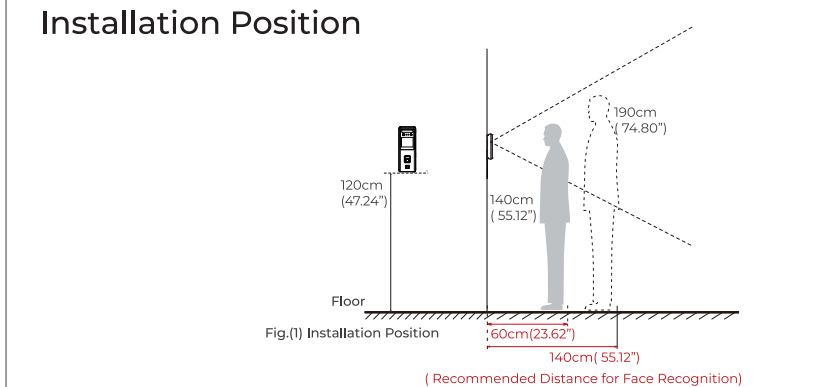

Suggested installation height (From device base to ground) is 1.2m (47.24") and the recognizable body height range is 1.4-1.9m (55.12"-74.80").

Installation Steps

- Keep the mounting bracket parallel with the ground and 1.2m distance to the ground. Drill 4 screw holes on the wall according to the mounting bracket.
- Please punch out the tail lines from the outlet hole before installing the mounting bracket and use the screws to fix the mounting bracket on the wall. Secure the device from the bottom and tighten the screws.

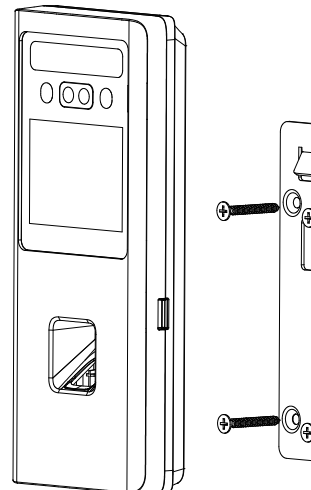

Access Wiring

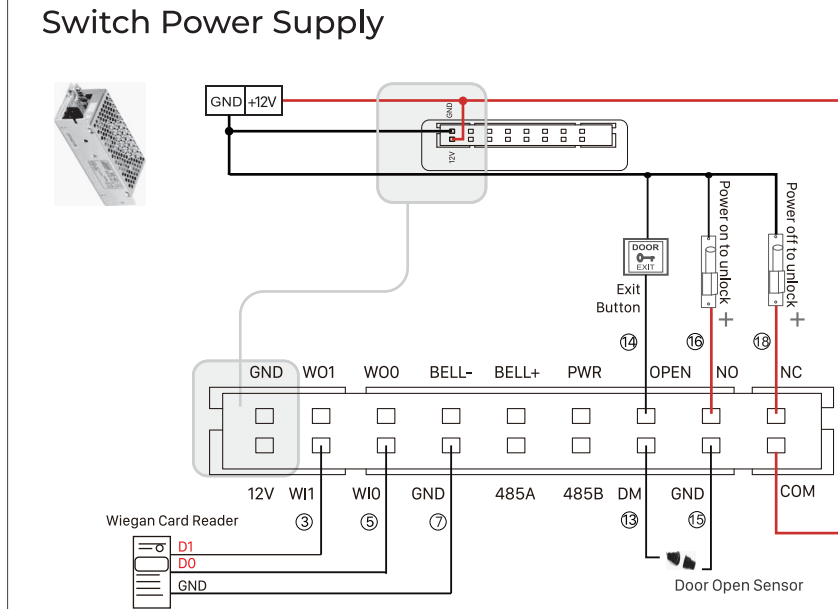

Access Control Power Supply

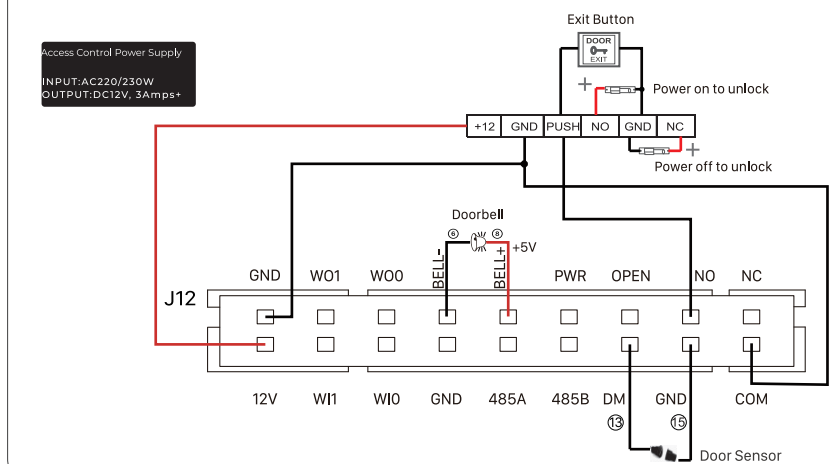

Quick Guide

After completing the Device Setup Guide please Click "☰", then enter the admin ID and password to access the main menu. (The default administrator account: ID is 0 and the password is 12345.)

Menu Option

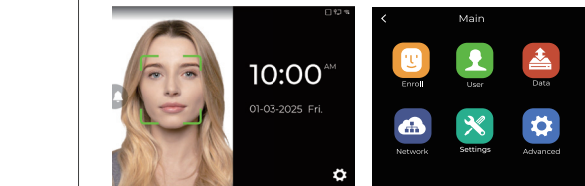

- Enroll:** Shortcut to register users' faces and fingerprint.
- User:** To Add, Modify, Delete, Search basic user information, and set Admin Level.
- Data:** Inquire about user data on the device. Include Record, Import, Export, Backup DB, Restore DB, Report Form.
- Network:** Set up the device network. Include Ethernet, Wi-Fi, Internet, Comm Mode and Cloud.
- Settings:** Device basic parameter settings. Include Device information, Time, Display, Basic Information, Update and self-test function.
- Advanced:** Include T&A (Time and Attendance), Application, Verify Mode, FN, and Auto FN.

Enroll

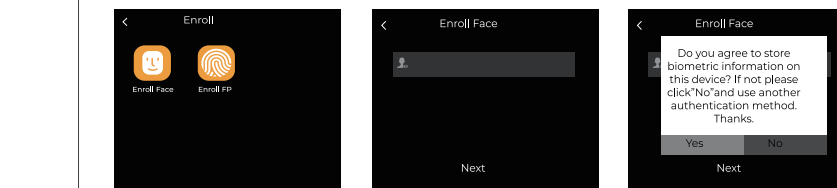



© 2025 Xthings Inc. All rights reserved.

Anviz and Anviz logo are trademarks of Xthings Inc. or its affiliates registered in the U.S. and other countries and regions. All other trademarks are the property of their respective owners.

Xthings Inc. 47703 Fremont Boulevard, Fremont, CA 94538. Engineered by Xthings, assembled in China.

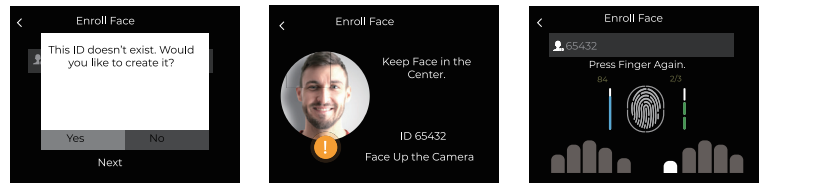

- 1 Tap "Enroll Face" or "Enroll FP", then enter the unique user identification number as User ID.
- 2 Tap "Yes" to agree the enroll biometric on the terminal and create a new User ID.
- 3 **Enroll Face:** Please adjust your face in the register area and stay until register success.
Enroll Finger: Please press the same finger 3 time on the sensor until register success.
- 4 Continue Enroll other users or tap "<" to return to the previous page.

User

Tap "User" icon to access the user management interface.

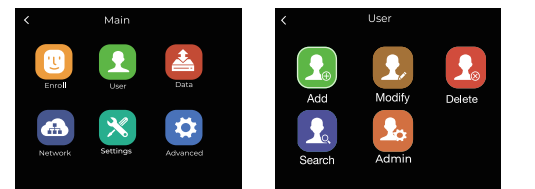

Add User

- 1 Tap "Add" to access the Add User interface.
- 2 Input the user's basic information on this page (Including User ID, Name, Password, Card ID, Enroll Fingerprint, Enroll Face, System default, Admin, Group ID, Schedule, Start date and Expiry date.)
- 3 Select the desired item and setting.
- 4 Tap "<" to save the configuration and return to the previous page.

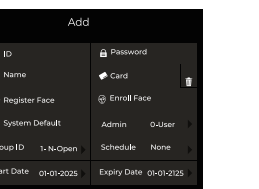

- User ID:** The User ID is required and unique for each user.
- User Name:** Enter the user name via the keypad.
- User Password:** Input the maximum 6 digits as a password.
- User RFID Card:** Swipe the RFID Card on the device's RFID Card area, it will display the RFID Card number in the text bar.
- Fingerprint:** Register the user's fingerprint for user authentication.
- Enroll Face:** Register the user's face for user authentication.

- System default:** Select to set up the verify mode for the user, including System default, Fingerprint, Face, ID->PW and Card.
- Admin:** The device supports different roles for the user. (Support 17 roles. The default is User) For detailed operating instructions, please see Section "Admin Level".
- Group ID:** The device supports 17 access control groups (The Default is Group 1, with whole-period access control permission).
- Schedule:** Select the shift for the user.
- Start and Expiry date:** Select the Start date and Expiry date for the user.

Modify & Delete User

Administrator can modify and delete the registered user information.

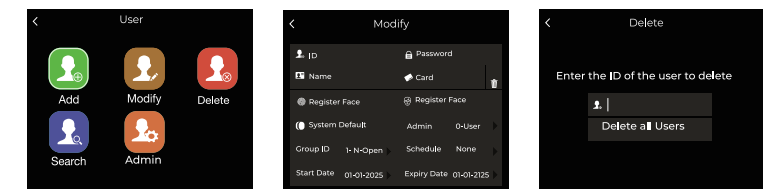

- 1 Input the registered user ID to modify the user information or input the User ID you want to delete.
- 2 Tap "Delete all Users" to delete all Users, the device will ask for confirmation. Input the super admin password to confirm the operation, default: "12345".
- 3 Tap "<" to return to the previous page.

Search User

Search users on this page.

- 1 Tap "Search" icon input the User ID to search the user.
- 2 Select the user to modify user information.
- 3 Tap "<" to return to the previous page.

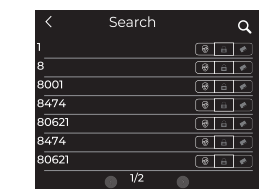

Network Setting

Tap "Network" icon to access the network configuration interface.

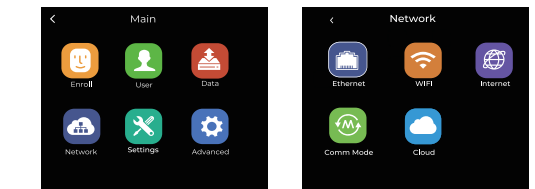

Ethernet

Please make sure that the network cable is already connected to the terminal. Set up the terminal IP address.

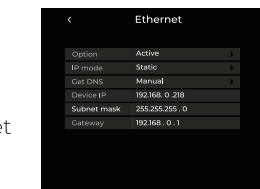

- Option:** Active or inactive the network communication based on cable.
- IP mode:** Select "Static" for fixed IP or "DHCP" for dynamic IP mode.
Static: Fixed IP address that doesn't change. In static IP mode, you need to manually enter the IP address of the device, please contact the system administrator to obtain the valid IP address.

- DHCP:** DHCP is a network server that will automatically provide and assigns an IP address, default gateway, and other network parameters to client devices. If the DHCP is disabled, the user can modify the Device IP, Subnet mask and Gateway.
- Get DNS:** Select between "Manual" or "Auto".
Manual: Get the DNS by set up in the "Internet" option.
Auto: Get the DNS by the local network system.

- Device IP:** Set the device IP manually in case of Static IP mode.
- Subnet mask:** Set the device Subnet mask manually in case of Static IP mode.
- Gateway:** Set the device Gateway manually in case of Static IP mode.

WiFi

Set up the wireless connection for the device.

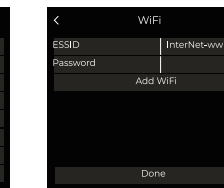
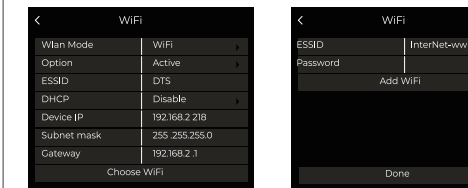

- Wlan Mode:** Two modes, you can choose WiFi mode or AP mode. Standard with WiFi Mode.
- Option:** Active or inactive the network communication based on WiFi.
- ESSID:** Display the connected WiFi ESSID.
- DHCP:** DHCP is a network server that will automatically provide and assigns an IP address, default gateway, and other network parameters to client devices. If the DHCP is disabled, the user can modify the Device IP, Subnet mask and Gateway.

- Device IP:** Set the device IP manually in case of Static IP mode.
- Subnet mask:** Set the device Subnet mask manually in case of Static IP mode.
- Gateway:** Set the device Gateway manually in case of Static IP mode.
- Choose WiFi:** Select the WiFi name in ESSID and input the password, then select "Done" on this page to connect.
- Add WiFi:** Add a new WiFi, modify the WiFi ESSID manually and click "done" to start the WiFi authentication process.

Internet

If you have already connected by Ethernet, we suggest select the Ethernet option. If you have already connected device by WiFi, we suggest select the WiFi option.

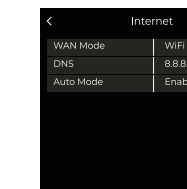

Cloud

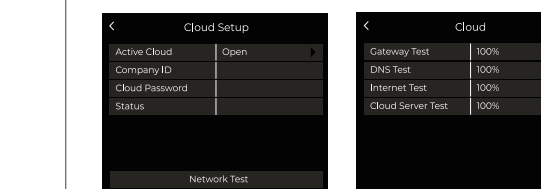

- 1 Choose Cloud.
- 2 Input Company ID and Cloud Password. This information could be taken from the Cloud account. (Setting > Company)
- 3 Wait for all Network Tests done without 0%.
- 4 Confirm the network icon and Cloud icon from the device desktop. The mark will disappear when it's connected.
- 5 Confirm the device connection from the Cloud account.

- Active Cloud:** Two modes, you can choose Open or Close.
- Company ID:** Input the Company ID registered in your CrossChex Cloud account.
- Cloud Password:** Input the password created in your CrossChex Cloud account.
- Status:** Display connection status, including Disconnect and Connected.
- Network Test:** Select to test the connectivity between the device and the CrossChex Cloud.

Warranty and Service

Anviz warrants that the hardware will be free from material defects in materials and workmanship, and will substantially conform to the applicable Documentation in effect as of the date of manufacture. This warranty is in effect for a period of three (3) years from the date of shipment by Anviz (the "Warranty Period"). For more warranty information about this product, please visit the link below: www.anviz.com/warranty-policy

Shipping Fees

The End Customer is responsible for the shipping fee for sending the product to customers is borne by Anviz (paying for one-way shipping). However, if the device is considered as No Fault Found, which means the device works normally, the returning shipment, too, is borne by End Customer (paying for round-trip shipping).

Return Merchandise Authorization ("RMA") Process

- Please fill out the Anviz RMA request form online <https://www.anviz.com/form/rma.html> and ask the technical support engineer for an RMA number. You will receive the RMA confirmation with the RMA number in 72 hours, after receiving an RMA number, please send the product in question to Anviz by following the Anviz shipment guide.
- When the inspection of the product is completed, you receive an RMA report from the technical support engineer. Anviz decides to repair or replace parts after user confirmation.
- When the repair is completed, Anviz notifies the user of that and sends the product back to you.
- An RMA number is valid for two months from the date of its issuance.
- An RMA number that is more than two months old is null and void, and in such a case, you need to get a new RMA number from Anviz's technical support engineer.
- Products without a registered RMA number will not be repaired.
- Products shipped without an RMA number may be returned, and Anviz will not be held responsible for any loss or other damage caused by this.



Scan the QR code to Software CrossChex Standard, or visit: <https://www.anviz.com/file/download/10470/Setup.exe>